



EFCA
YOUNG PROFESSIONAL OF THE YEAR
2018

Personal details / Entry Form

Full name: Fredrik Skaug Fadnes

Nationality: Norwegian

Birthday: 19.02.1986

Age as of 31/03/2018: 32

Company: Norconsult

Location: Sandvika, Norway

Member Association: RIF member

Contact details

E-mail address: Fredrik.skaug.fadnes@norconsult.com

Office phone number: +47 92097135

Cell phone number: +47 92097135

Instructions for completing this form



Note to candidates

Each section and sub-section may be expanded as required. The completed entry form should be no longer than **16 pages in total**. Section A is to be completed by your employer, and Section C by the client.

All entries should be submitted in English. Any annexes in other languages should be accompanied by an English translation, or will not be taken into account.

The form should be returned to your national association. They will forward it to the EFCA Secretariat.

You will be informed of the results of the competition at end of April 2018.

Good luck!

For those participating in the FIDIC YP competition

The requirements stipulated in the respective EFCA and FIDIC YP competitions coincide largely for 75%. The following three FIDIC competition requirements are entirely covered in the EFCA application:

- Technical achievements (see Section B in this template) (50%)
What is 30% for EFCA
- Leadership achievements (see Section C in this template) (15%)
What is 40% for EFCA
- Social and community contributions (see Section B in this template) (10%)
What is 30% for EFCA

However, EFCA YPs interested in submitting an application for the FIDIC YP competition should complement their EFCA application with the following two extra requirements.

Applicants should demonstrate:

- Contributions to consulting engineering industry (15%)
- Contribution to consulting engineering associations (10%)

Section A. EMPLOYER'S RECOMMENDATION

Fredrik is a natural nominee as candidate for young professional of this year, based on his good attitude, communication skills and great achievements made during his academic and professional career.

Fredrik has high academic skills, leaving the Norwegian Technical University of Science and Technology with top honors. His field of subjects was mainly within heat and energy processes and his thesis was about calculation of particle compilation using static and dynamic particle models. He achieved grade A for his thesis.

He started his professional career at Norconsult in 2011, being his first employer. Norconsult is Norway's largest and one of the leading multidisciplinary firms in the Nordic region.

Natural gift for communication and a high level of empathy

From day one, Fredrik showed a great talent and positive attitude towards the various challenges he received. His main interest is in process design and from the very beginning he has been hunting the most energy and cost efficient solutions, based on close communication with the client and our senior personnel. His learning curve has been steep as he is eager to accept new challenging projects and tasks. We have learned that he can be trusted to deliver quality according to the client's expectations.

Fredrik has a natural gift for communication and a high level of empathy. The importance of these abilities in his day-to-day work cannot be underestimated. Feedback from internal and external clients are in general very good and they always come back to Fredrik with new tasks. His role has grown fast from a general back-office position to a position with direct client contact and that with great success. He is a solution minded person and has been handling challenging clients and suppliers in a way that have given him respect and trust. Fredrik is also a person letting the case or situation go ahead of himself.

Excellent pedagogical and communicative skills

Fredrik has already been leading several interdisciplinary tender processes. This responsibility includes understanding of the task, offer strategy, progress planning, coordination between the disciplines, designing the offer, meeting deadlines and contract negotiations. He has been successful with his tender work and the main success criteria is his understanding and presentation of the problem the client would like to have solved.

His excellent pedagogical and communicative skills have made him a requested lecturer. He has held many presentations at various professional seminars in Norway as well as for clients and professional organizations. We receive only positive feedback from his presentations and he is a great ambassador for our company.



Contributing and leading several internal improvement

Despite of his young age, Fredrik is contributing and leading several internal improvement projects within his department, the most important being the Energy production group. The aim of this group is to further develop good working methodology and supportive documentation to ensure that the company deliver high quality and cost-effective solutions to the client within this field. He has taken personal responsibility to broaden our field of competence when he sees the market is asking for it, one example being solar energy, where he now possess our leading competence within this field.



Eager to contribute and took a lead position

He is also active taking social responsibility within the company. He became early a member of the Younger Council at Norconsult. This council is established to represent the younger employees of the company and to speak their case directly to the top management. This council has helped to make Norconsult a more attractive employer for young professionals. Fredrik has also been a member of various committees arranging internal social gatherings.

When the tender documentation from Stavanger municipality came for the Triangulum project, Fredrik was eager to contribute and took a lead position in the tender process. The premises for the process was a competition between preselected consultancy companies to come up with the best solution for energy supply to the Stavanger city hall, a swimming hall and a municipality administration building based on local energy sources and minimum 75% renewable energy. Fredrik's proposed solution was well received by the municipality, mainly due to its degree of innovation, and Norconsult was selected to bring the ideas into a concept phase. From there Fredrik had a central role in the project until the energy plant was put into operation in June 2017.

Name: Lars Sigurd Eri

Job title: Department leader

Managerial relationship to candidate: His manager

Section B. THE PROJECT

The three point project Triangulum is one of currently nine European Smart Cities and Communities Lighthouse Projects, set to demonstrate, disseminate and replicate solutions and frameworks for Europe's future smart cities. The flagship cities Manchester (UK), Eindhoven (NL) and Stavanger (NO) will serve as a testbed for innovative projects focusing on sustainable mobility, energy, ICT and business opportunities. The project consortium combines interdisciplinary experience and expertise of 22 partners from industry, research and municipalities who share the same objective and commitment to develop and implement smart solutions in order to replicate them in the three follower cities Leipzig (D), Prague (CZ) and Sabadell (ES). The overall budget of Triangulum is 30 million Euros (2015-2020). The European Commission funding (Horizon 2020) totals 25 million Euros. The project is coordinated by Fraunhofer IAO in Stuttgart and supported by Steinbeis-Europa-Zentrum.



The Stavanger region is regarded as one of the most innovative regions in Norway; it has ten years in a row been appointed the best business region in Norway (NHO) and has a practice for close triple helix cooperation among businesses, academia and public sector. The region aims at a high degree of

knowledge transfer between sectors and areas of business, such as subsea to space, space to health, offshore to onshore services.

The Stavanger Triangulum consortium consists of Stavanger municipality, Lyse, The University of Stavanger, Greater Stavanger Economic Development and the Rogaland County Council.

The Stavanger's Triangulum energy plant was initiated under the Triangulum umbrella as a competition between selected consultancy companies to come up with the most innovative solution for energy supply to municipal buildings downtown Stavanger based on local energy sources and minimum 75 % renewable. Norconsult won the competition and brought the project forward into a concept phase and later detailed engineering, contracting and construction.

B.2 Innovative characteristics of the project:

Degree of innovation was an important criterion in the competition initiated by the municipality of Stavanger. In Norconsult's winning proposal, Fredrik had a wide approach to potential solutions with main focus on utilizing energy from a nearby underground sewage pipeline. Other potential sources listed were energy from the nearby sea, solar and geothermal energy as well as energy from a nearby train tunnel.

Energy plants utilizing energy from sewage is already established several places in Norway. However, these plants are based on high cost technical solutions requiring a high energy demand to defend the rather large investment. In Stavanger, the energy demand could never defend such investment and we had to look for a more cost-effective solution. By introducing a technology never used in Norway and never in such large scale in Europe, we were able to

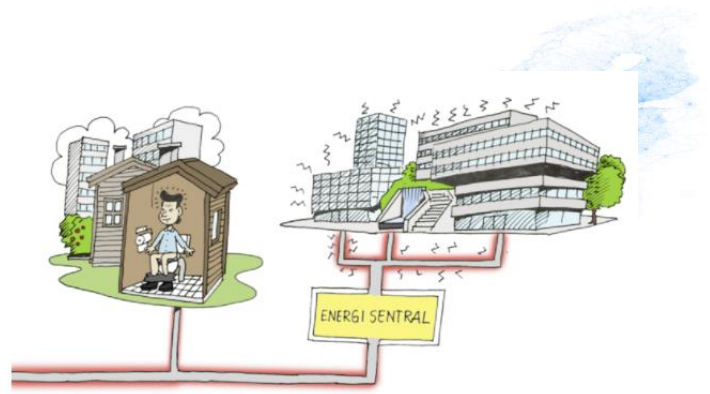

defend the investment based on the given energy demand. The technology consists of a 300-meter-long row of heat exchangers installed directly in the 5000 mm in diameter sewage pipe. Water circulates inside the heat exchangers to collect heat or cold from the sewage. The sewage pipe is 100 meters from the energy central and an underground tunnel is drilled between them. Inside the energy central a heat pump rises the temperature to the required level, alternatively the water is used for direct cooling. Sun collectors are installed on the roof of one of the municipal buildings to heat tap water and surplus energy from the local swimming pool is also utilized in the system. A biogas boiler is installed to cover the peak demands. The biogas is produced in a biogas production plant nearby, based on the same sewage the energy plants gets its heat and cold from. The energy source is therefore 100 % local and 100 % renewable.

The plant has so far won two prizes in Norway, both for its degree of innovation and level of transferability.

B.3 The YP's role in, and specific contribution to, the project:

Fredrik had a leading role in the tender process. He addressed the requirements in the tender documents in our offer in a way that convinced the client that Norconsult was the right partner to help them meet their goals for the project. He presented the offer in the contract meeting.

When Norconsult was awarded the contract, Fredrik initially had a role as an assistant to the discipline leader, process. However, as the project proceeded, Fredrik got more and took more responsibility from the discipline leader. He built up trust with the client and more of the communication went via him. At the end of the concept phase he was in practice the discipline leader. Fredrik kept progress up and was the main contributor in developing the various concepts. He made the LCC-analysis, wrote the report and presented the report to the client. Fredrik always used the original discipline leader for quality assurance and as sparring partner.

After the first phase and when the concept was chosen, we prepared a new offer to the client for the detailed engineering and construction phase. This tender process was also in competition with other consultant companies. Fredrik was Norconsult's bid leader and

coordinated preparation of all tender documentation from our side. He presented and negotiated our offer with the client and again we were awarded the contract.

This time Fredrik was sold in as the discipline leader and project manager assistant. The client gave his role high score in their evaluation of the offer. Again, he convinced and built up trust with client in his new role as the project proceeded. He prepared all the process drawings and build up a 3D-model in AutoCAD for the energy central. He coordinated with the other disciplines and made sure that all documentation was quality assured according to our internal quality system. He prepared the requirement specification within his discipline and had the technical responsibility when the equipment suppliers were contracted.

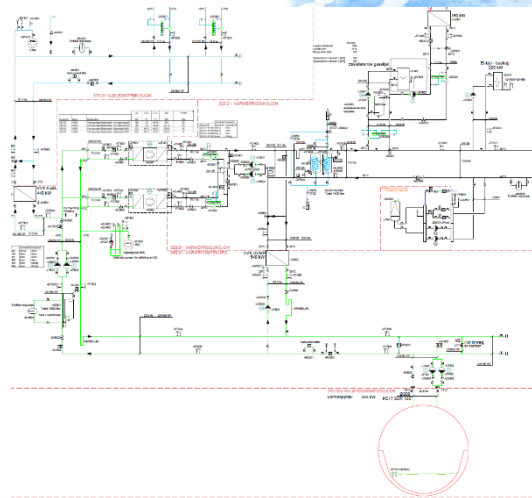

During the construction phase he had a role as construction leader assistant and handled more or less all communication with the equipment suppliers. He followed up and made sure that all suppliers delivered according to their time schedule. He handled compensation requirements from the equipment suppliers on behalf of the client. He was in close dialog with the client for reporting purposes. He was often on site for troubleshooting and followed up afterwards to make sure problem was solved and progress kept.

The project delivered according to budget and time schedule. Stavanger municipality has given Fredrik access to the control system of the energy central, so he is able to follow up and adjust the plant in the initial phase of its operation.

B.4 Communication with the client/end user:

Fredrik's communication skills, both written and oral, has been an important success factor, initially to win this project, and later for the smooth implementation of the concept and construction phase.

He wrote and prepared the offer to the client and participated in the contract meeting to present the offer. His calm attitude and pedagogical presentation convinced the client.

In the concept and implementation phase he used his communication skills to keep the participants in the project focused on their tasks. In this type of project, with many actors and tight time frame, conflicts might often arise, and the actors lose their focus on the progress. Fredrik was able to foresee many of these potential conflicts during the various project phases and in most cases cleared them out before the conflicts arose. When he was not able to foresee them, his calm attitude, empathy and good communication skills made the conflicts not escalate.

Our client saw Fredrik's talent for communication and as the project proceeded, more and more of the communication between the client and Norconsult and between the client and the other actors in the project went through Fredrik. The client also used Fredrik during

amendment negotiations with EU/INEA, where he explained challenges and solutions very well and in good manners according to the client.

B.5 Describe the project end results and the benefits to the client/end user:

Stavanger municipality had clear goals for this project. They wanted an innovative energy solution for heat supply to three municipal buildings downtown Stavanger based on local energy sources and minimum 75% renewable. They got an innovative energy solution for heat and cooling supply to their buildings based on local energy sources and 100% renewable energy. In addition, there is a reserve capacity in the energy central for potential future energy supply to another four private office buildings in the same area.

The project has gained much recognition in the academic environment and has so far received two prizes;

- <http://triangulum-project.eu/index.php/2017/12/11/water-industry-award-goes-to-triangulum-project-in-stavanger-stavangers-central-energy-plant-awarded-as-first-of-its-kind-in-norway/#more-1228>
- <https://www.stavanger.kommune.no/nyheter/arets-varmepumpepris-gikk-til-energisentralen-i-stavanger-kommune/>

The municipality of Stavanger has made their own promotion video of the project:

- <https://www.youtube.com/watch?v=Gj3ADgagkZk>

Section C. CLIENT'S APPRECIATION OF THE CANDIDATE

The client is Stavanger municipality with their representative, Ernst Olsen, as the project owner.

The project has been through two phases; first a concept evaluation phase, thereafter a phase with detail engineering, contracting and construction. Norconsult was awarded the contract for both phases in competition with other consultancy companies.

Fredrik had a central role through both phases, as assistant for Norconsult's project manager and in effect the main contributor with both detailed and overall overview from the consultant's side. He represented the continuity throughout the project and became gradual the main person for communication with both us, as the client, and the equipment suppliers. Fredrik was a core expert for us during the Amendment negotiations with the EUIINEA office and explained the challenges and the solutions very well and in good manners.

After the project was completed, we evaluated Norconsult based on the following criteria's, where 5 points is top score and 1 point is low score;

Reliability on delivery (5 points)

The timeframe for the first phase of the project was only three months, due to the tight deadlines in the EU project. The project had weekly project meetings, with the municipality in charge. Norconsult met all deadlines as well as the cost frame.

Quality, problem solving and level of competence (5 points)

The quality was good on all deliveries. The project's first phase was an R&D project, with an ambition to find innovative solutions based on local energy sources. Innovation is challenging within the building and construction industry, adding the tight delivery schedule and the fact that the project immediately went over to a detail engineering phase. As for other construction projects there were disagreements, but these were solved by close communication and a solution-oriented attitude.

Cooperation and follow-up (5 points)

Norconsult showed great seriousness, positive attitude and was dedicated throughout both phases of the project. They were also an active contributor during the tenderer conference we arranged up front the tender process for the detailed engineering phase.

Cost and invoicing (5 points)

Both phases were based on fixed-price contracts, being invoiced according to contract and with minimum added costs.

Norconsult completed the project according to the preconditions given in the tender documents. The assignment was conducted with high professional quality, according to schedule and agreed cost frame.

Stavanger 15.03.2018

Ernst Olsen

Job title: Manager Operation and energy section

Company: Stavanger municipality

Section D. CV OF THE CANDIDATE



Curriculum Vitae



Personal information

First name(s) / Family name(s)

Fredrik Skaug Fadnes

Business Address

Vestfjordgaten 4, 1338 Sandvika

Phone number(s)

+47 92097135

Cell: +47 92097135

E-mail address

fredrik.skaug.fadnes@norconsult.com

Nationality

Norwegian

Date of birth

1986-02-19

Work experience

Dates

Current (from August 2011)

Occupation or position held

M.Sc. Energy and Environmental Engineering

Main activities and responsibilities

Energy consulting
Conceptual and Detail Design of Thermal Energy Systems.
Project Management.
Feasibility Studies.

Name and address of employer

Norconsult AS

Type of business or sector

Multidisciplinary consultancy

Dates

2005-2006

Occupation or position held

Communications Operator

Main activities and responsibilities

Installation, configuration and operation of the Air Force's field communications equipment.

Name and address of employer

The Norwegian Air Force

Type of business or sector

Military Sector

Education and training

Dates

2006-2011

Title of qualification awarded

Master of Science

Principal subjects/occupational skills covered

Energy and Environmental Technology
Heat and Energy Processes
Thermodynamics
Fluid dynamics
Automation



Name and type of organisation providing education and training

The Norwegian University of Science and Technology (NTNU)

Level in national or international classification

Level 7 (Norwegian Standard Classification of Education)

Dates

Add separate entries for each relevant course you have completed, starting from the most recent.

Title of qualification awarded

Master of Science

Principal subjects/occupational skills covered

Heat and Energy Processes
Thermodynamics
Fluid Mechanics
Automation and Control Systems
External education at the Vienna University of Technology (2009-2010)

Name and type of organisation providing education and training

The Norwegian University of Science and Technology (NTNU)

Level in national or international classification

Level 7 (Norwegian Standard Classification of Education)

Other language(s)

English, German

Self-assessment

European level (*)

English

German

Understanding				Speaking				Writing	
Listening		Reading		Spoken interaction		Spoken production			
C2	Proficient user	C2	Proficient user	C1	Proficient user	C1	Proficient user	C1	Proficient user
B2	Independent user	B2	Independent user	B1	Independent user	B1	Independent user	B2	Independent user

Social skills and competences

Cooperative – especially good at making all the project participants, including the project owner, project manager, consultants and entrepreneurs work together as a team, while respecting and understanding the other participants.
Always honest.
A firm believer of the sharing of tools and information.
Forging and maintaining client relationships.

Organisational skills and competences

Very good at seeing the grand design while understanding the importance of the smaller details in a project and can be a project manager and a detail designer simultaneously.
Is always involved in five to ten different projects at the same time, combining a vast number of tasks and problems for several clients, who all are expecting the full attention and time of the consultant.

Technical skills and competences

Heat pump system specialist and the company's foremost expert of ground heat and sewage heat systems.
Calculations of building and process energy and power demand.
Conceptual and Detail Design of Thermal Energy Systems.
Solar Energy Expert.
The implementation of Energy Certification and Management.

Computer skills and competences

Advanced user of Excel, including Visual Basic.
Expert user of Earth Energy Designer, for design of ground heat and cooling systems.
Expert user of PVSyst and T*Sol, for calculations of Photovoltaic and Solar Heating production.
Expert user of AutoCAD/MagiCAD for computer-aided design.
User of Revit, software for building information modelling.

Other skills and competences

Very good at making advanced engineering problems understandable for non-engineers, such as clients and students.
Has an excellent memory.

Hobbies and activities	Running and Cross-country Skiing Film (favourites include Raiders of the Lost Ark, A Serious Man, Reprise and Tinker Tailor Soldier Spy. Vienna, the greatest city in the world. Team member of several quiz teams. Voluntary Math and Science Teacher for the Red Cross.
Papers published	
Public speaking experience	Speaker at several conferences including the Norwegian Heat Pump Conference 2018 and the Energy Forum of the Norwegian Alliance for Green Buildings. Preferred presenter of the Municipality of Stavanger's new energy central plant, including presentations for representative from the European Union. Presentations includes: - Basic Heat Pump Technology - Ground heat and sewage pump systems - Solar Energy
Membership of professional organisations	The Norwegian Heat Pump Society (NOVAP). The Norwegian Solar Energy Society. Norsk VVS - The Norwegian Society for Energy and Environmental Technology. Tekna - The Norwegian Society of Graduate Technical and Scientific Professionals.

